



# Stakeholder Information Meeting Wastewater And Stormwater Facilities Plans

May 11, 2017



- Introduction Lenise Marrero
- Wastewater Facilities Plan Eliza Jane Whitman & Sarah Munger
  - Overview
  - Existing and Future Conditions
  - Q&A
- Stormwater Facilities Plan Azya Jackson & Mark Hanna
  - Overview
  - Existing and Future Conditions
  - Q&A



# Wastewater Facilities Plan



# Wastewater Facilities Plan

## Purpose

To address future system needs through 2040

## Why are we doing it?

To optimize the use of the City's water assets

- Recycled water
- Advanced treated water
- Evaluate conservation impacts
- Meet permit requirements
- <sup>4</sup> Sustainability

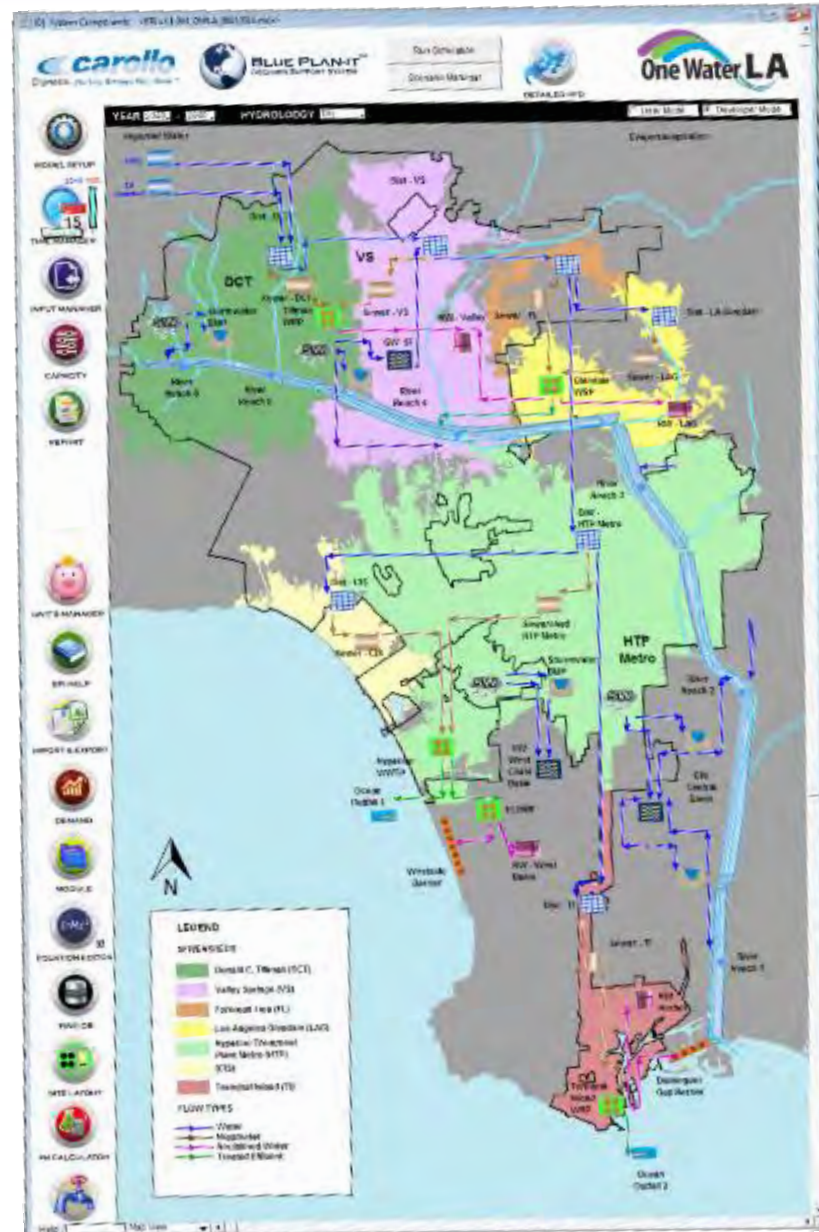



# Leveraging Previous Plans

## 2012 Recycled Water Master Plan

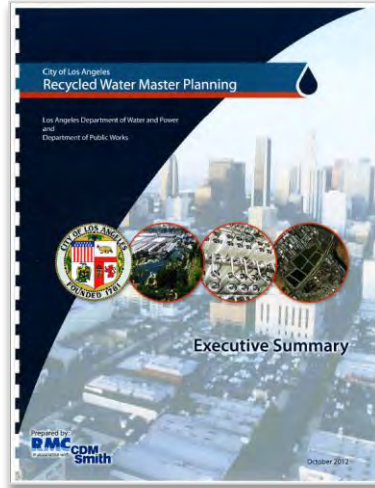

## 2015 Urban Water Management Plan



## 2006 Water IRP

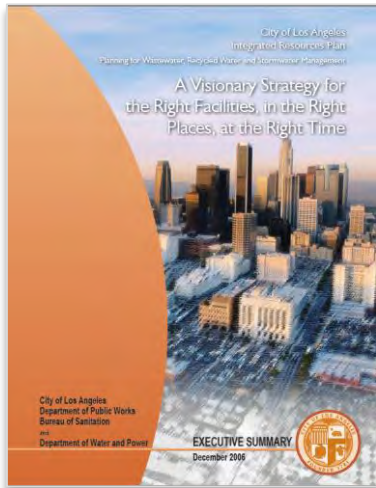

## FY 2015/16 Recycled Water Annual Report

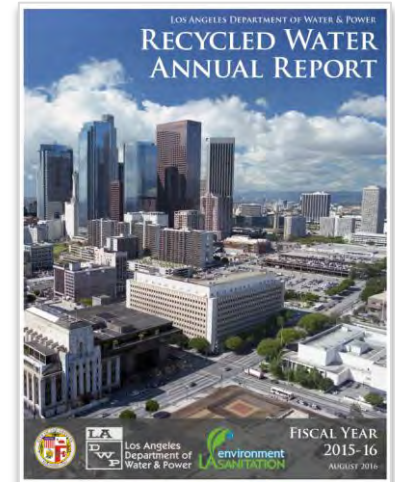



# Facilities Plan Overview

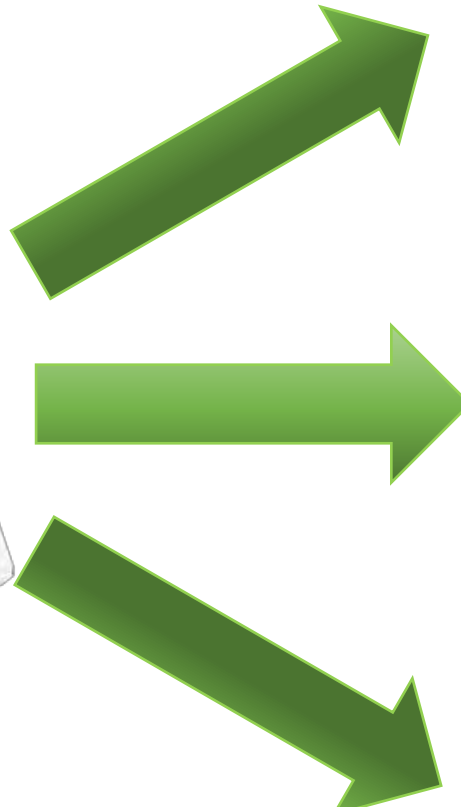

1. Summary
2. Introduction
3. Regulatory Background
4. Conveyance System
5. Treatment Analysis & Process
6. Flow Analysis
  1. Existing Conditions
  2. Future Conditions
7. In Progress Projects
8. Future Condition Concepts
9. Wastewater Improvement Program

# Wastewater Infrastructure

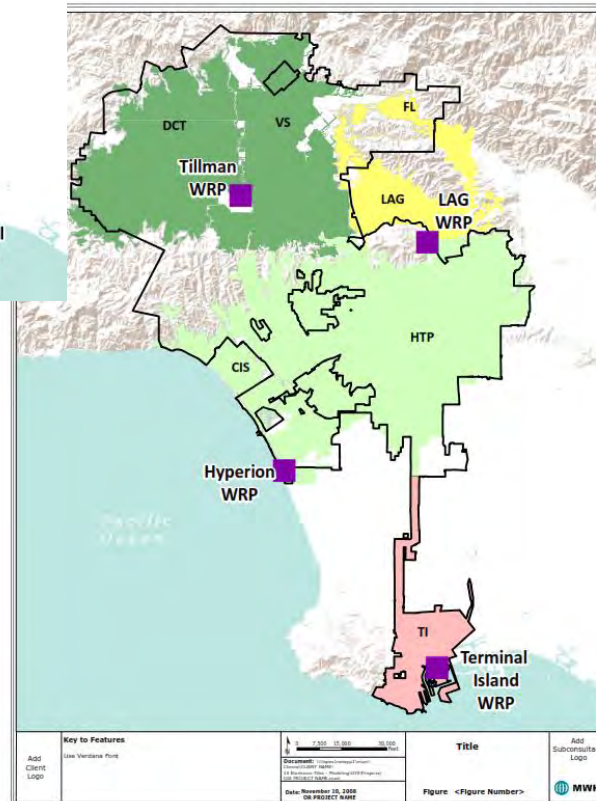
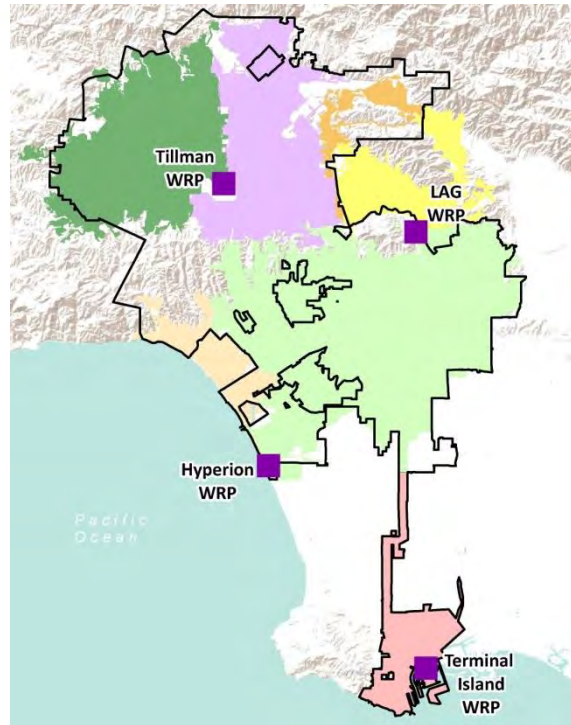

- Four water reclamation plants
- Seven sewersheds
  - Hyperion Sewershed (includes DCT and LAG due to by-passing option) has 6,000 miles of sewers
  - Terminal Island Sewershed has 240 miles of sewers

- Site visits at each plant
- Review existing conditions
  - Identify and locate new facilities since 2006 IRP
  - Note modifications to existing equipment
  - Document changes in O&M activities
- Update regulatory requirements
- Evaluated flows

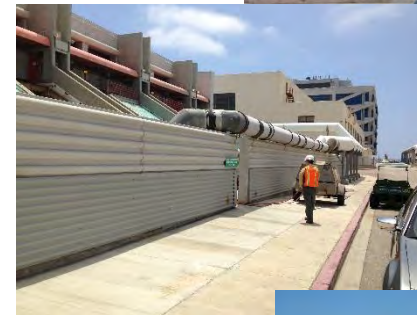

# Wastewater Flows

- **Donald C Tillman WRP**
  - Existing = 32 mgd
  - Projected Flow in Year 2040 = 71-90 mgd
- **LA/Glendale WRP**
  - Existing = 14 mgd
  - Projected Flow in Year 2040 = 24 mgd
- **Hyperion WRP**
  - Existing = 250 mgd
  - Projected Flow in Year 2040 = 284 mgd
- **Terminal Island WRP**
  - Existing = 14 mgd
  - Projected Flow in Year 2040 = 18 mgd

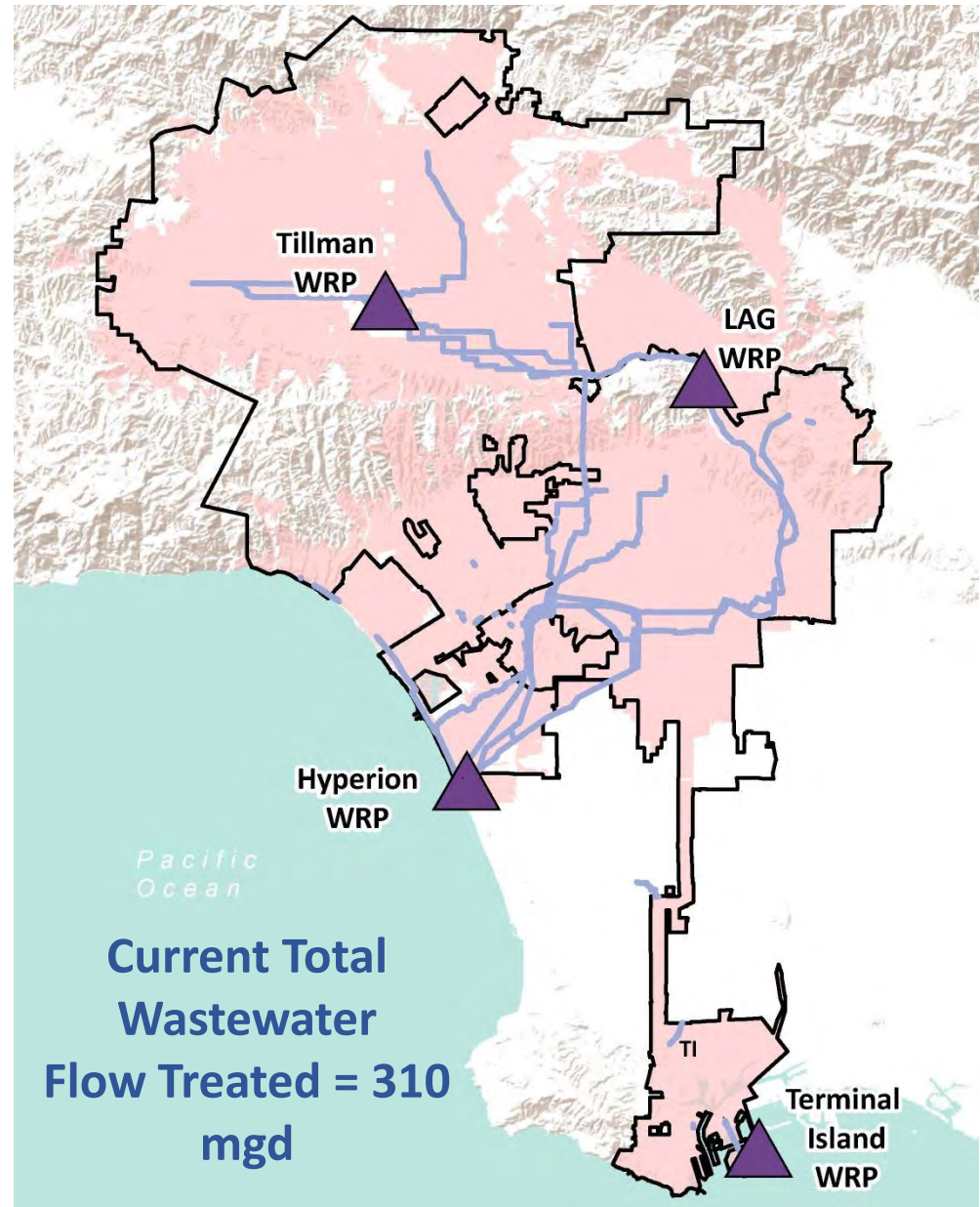



# Wastewater Facilities Plan

- Existing conditions
- Repairs, rehabilitation & upgrades required
- Projected flows
  - Existing and future flows (conservation, population growth)
  - Future system needs through 2040
- Regulatory requirements
- Triggers – *when should a project be initiated?*
- Future alternatives & concepts
  - Scope
  - Estimated costs
- Capital Improvement Program

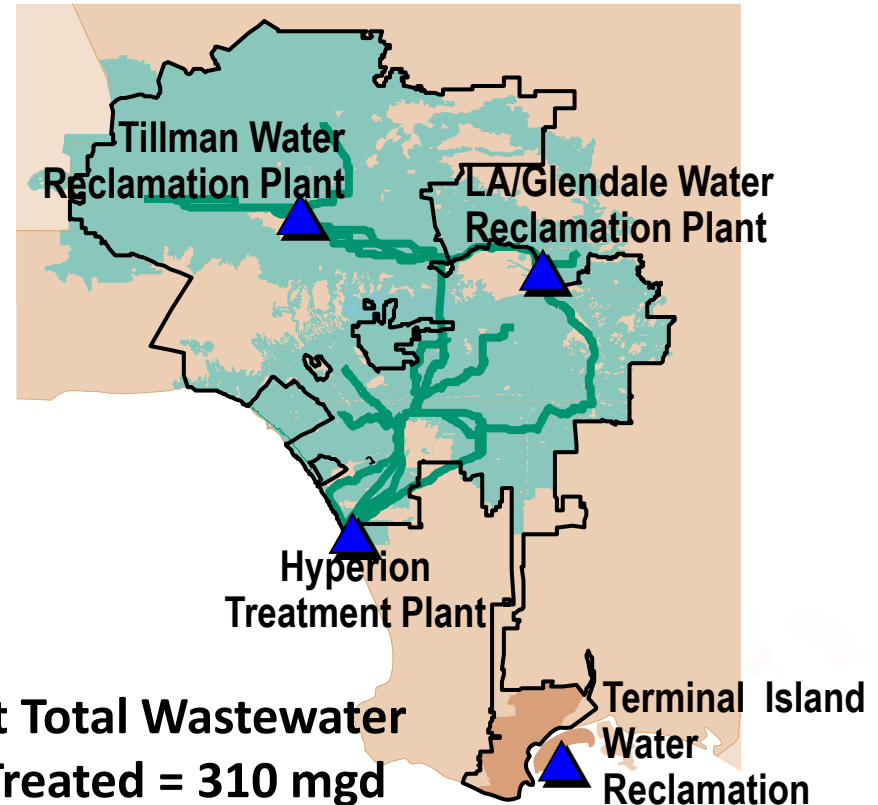



# Climate Resilient Infrastructure

- **DCTWRP**

- Raising flood protection level
- Backup power generation analysis

- **LAGWRP**

- Flood wall and gates
- Backup power generation
- Backflow prevention gates on outfall to LA River
- Submarine door evaluation and maintenance

- **HWRP**

- Lining of Coastal Interceptor
- Vista Del Mar evaluation structural stability
- Enhance slope stabilization and length retaining wall
- Evaluate impacts of a tsunami on outfalls

- **TIWRP**

- Flood wall and gates
- Backup power generation analysis

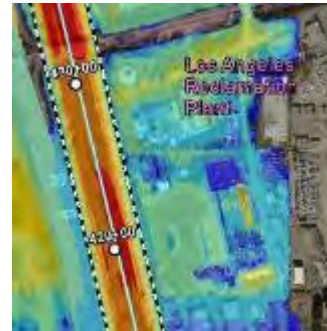



# WRPs: Solution to Water Resiliency



*LA's Water Reclamation Plants are essential to the success in meeting the Mayor's goals for local water supply*

- Off-setting purchased water demand
  - Advanced treated water – potable reuse
  - Recycled water addressing industrial users
  - Recycled water for irrigation water demand
- There will always be a need to purchase
  - Based on demand in the City
  - Infrastructure





# LA's Estimated Reductions in MWD Purchases

**FY 2015-16 Actual**  
**Total Demand: 486,734 AF\***

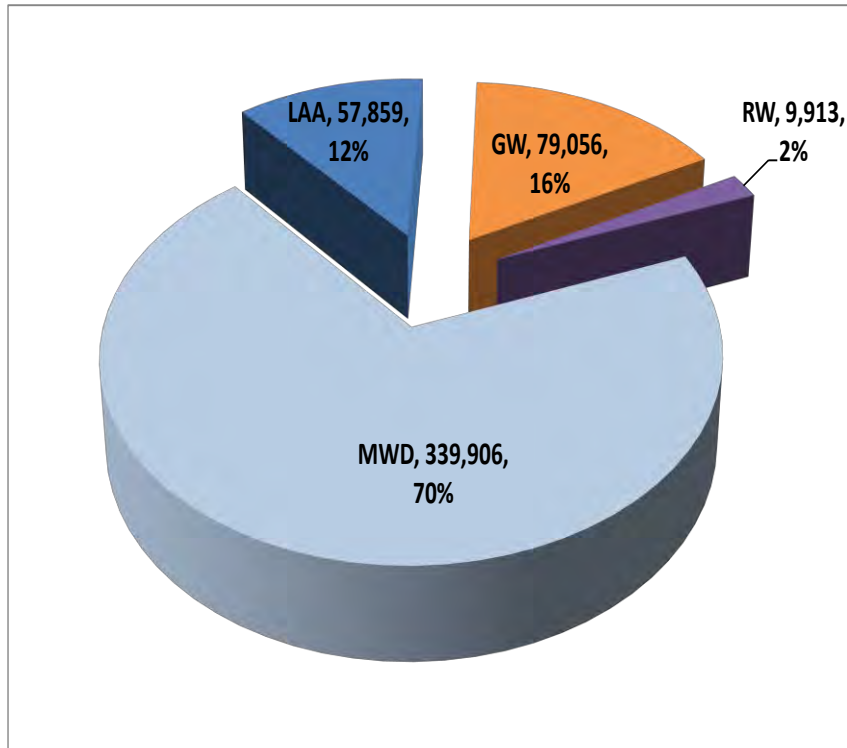

**FY 2017-18 Projected**  
**Total Demand: 475,300 AF (155 MG)**

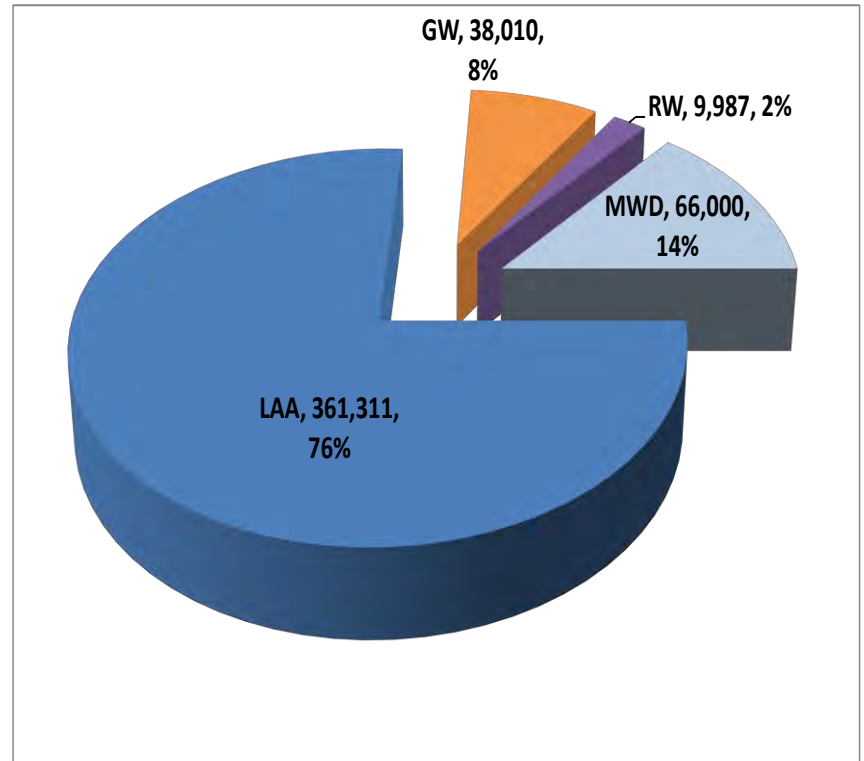

\*Not including storage change of -3,509 AF



# Key Impacts to WRP Facility Decisions

- Potable Reuse Future Regulations
  - Indirect Potable Reuse (IPR)
  - Direct Potable Reuse (DPR)
- Triggers
  - IPR/DPR Regulations
  - Additional flow to Donald C Tillman WRP
  - Minimum Flow Requirements with LA River
  - Sustainable City plan yield requirement
  - Stormwater quality compliance
  - Funding
  - New regulations on wastewater treatment discharge
- Policy Directives set by the Mayor
- Climate Resiliency





# Water Reclamation Plants



# Donald C. Tillman Water Reclamation Plant (DCTWRP)

## Current Conditions

- Plant Capacity: 80 mgd
- Sewershed: San Fernando Valley/  
NW section of LA
- Average treated flow (2016): 32  
mgd
- Pilot to test advanced technologies  
for Groundwater Replenishment  
Project





# DCTWRP Effluent Flows

## Treated Water Uses (tertiary):

- Balboa and Wildlife lakes
- Japanese garden
- Irrigation
- In-Plant Use



Recycled Water use		Total Recycled Water (Potable Offset)		Additional Water Beneficially Reused (Weir, Lakes, In-plant)	
Customer	mgd	mgd	AFY (x 1000)	mgd	AFY (x 1000)
DWP: Irrigation & Cooling Towers	2.9	2.9	3.2	29.0	32.5
Lakes	23				
In-Plant Use	2.4				
Operational Safety Weir	3.6				



## Near-Term

- Add facilities and modify treatment to produce up to 30 MGD Advanced Water Treatment (AWT)
- Interim ozonation pilot plant (6 mgd)
- LASAN/LADWP completing the Groundwater Replenishment project
  - Recharging San Fernando Valley aquifer (City Water Rights)
  - Advanced Water Treatment Facility by 2022





## Considerations For the Future (2040)

- Re-route 12-15 mgd of sewer flows
- Build new sewers and pump stations (EWVIS)
- Divert stormwater into the sewers using:
  - Low Flow Diversions (LFD) structures
  - Wet Weather Divisions (where practical)
- Accept new housing development flows
- Additional water reclamation facilities
- Recirculating lake flows
- Groundwater injection
- Los Angeles Aqueduct Filtration Plant



# DCTWRP: Indirect Potable Reuse

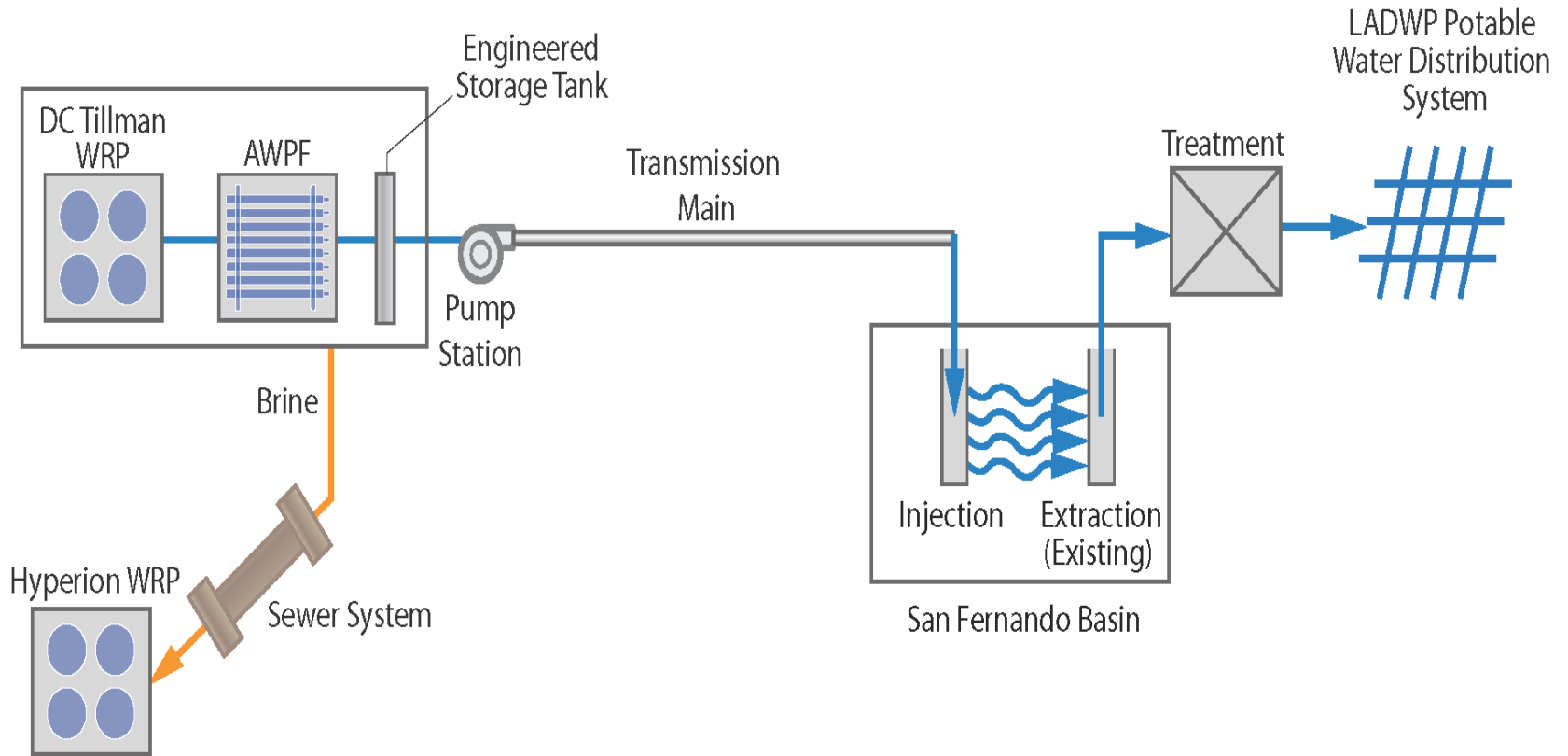



# DCTWRP: Direct Potable Reuse

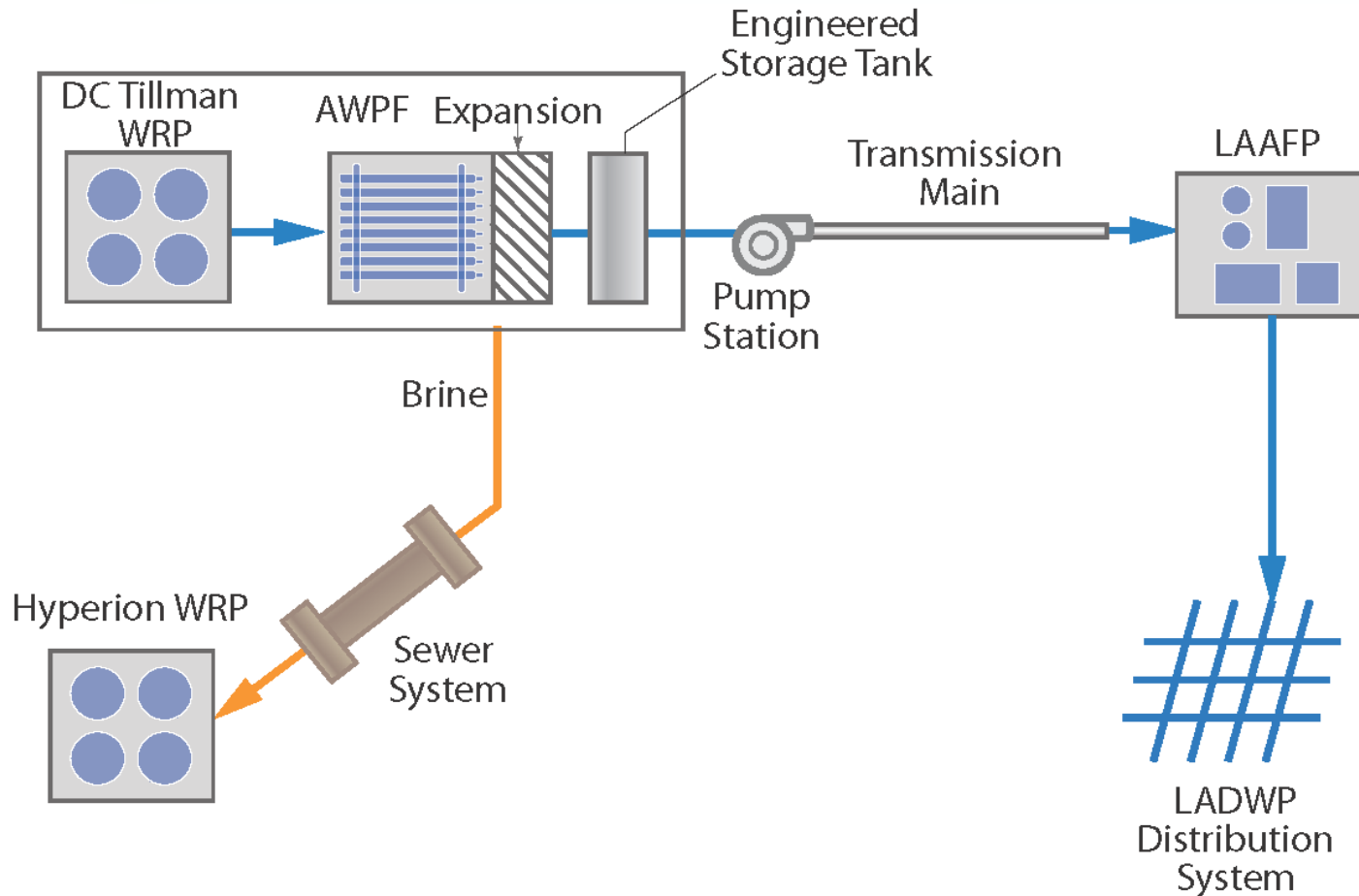



# LA-Glendale Water Reclamation Plant (LAGWRP)

## Current Conditions

- Plant Capacity: 20 mgd
- Sewershed: NE section of LA
- Average treated flow (2016): 14 mgd
- Water reuse for Glendale (50%) and LA (50%)
- LA River flows - City water rights
- Delivery of tertiary treated water for:
  - Glendale irrigation
  - Irrigation in Griffith Park
  - In-Plant Use





## Near-Term

- 5 MG primary effluent flow equalization tank
- Increase of recycled water use for irrigation by:
  - Proposed - City of Glendale expansion
  - City of LA with expansions including Elysian Park and Downtown LA



## Considerations For the Future (2040)

- Evaluating small scale DPR option to LADWP Headwork's Reservoir (near LA Zoo)

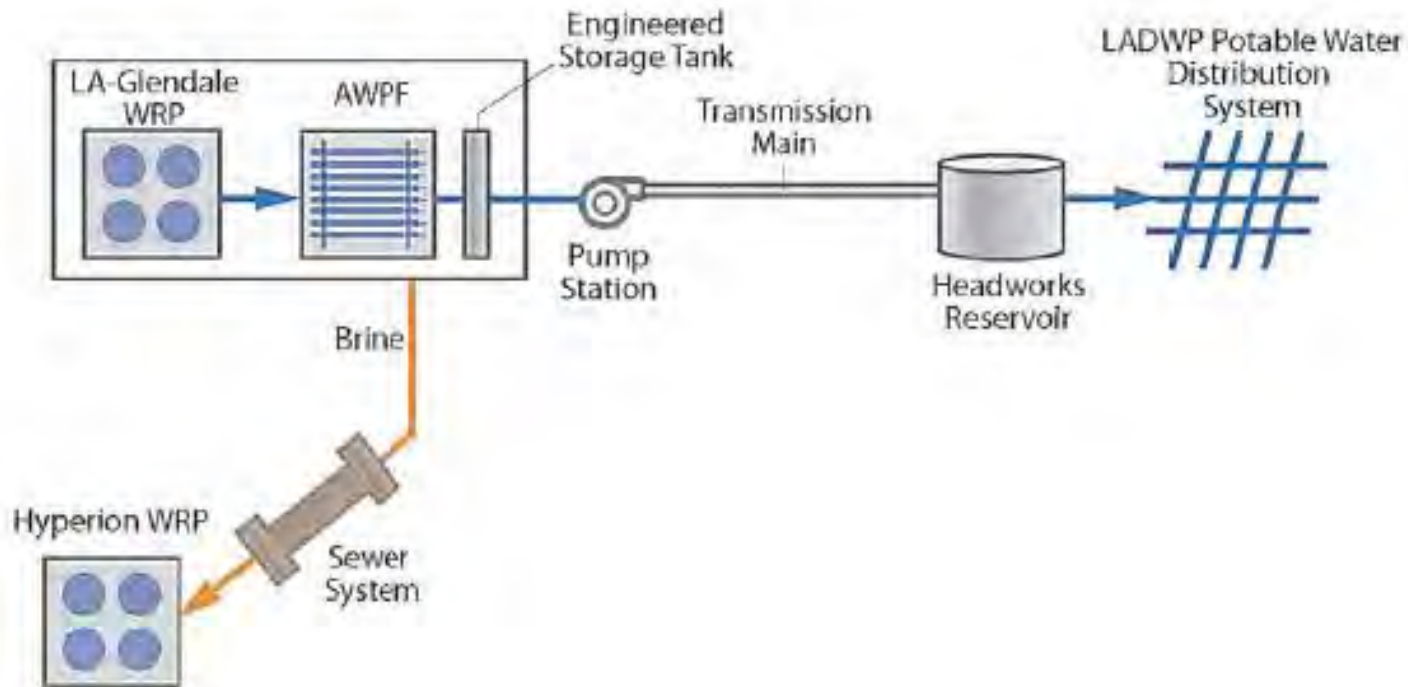



# Hyperion Water Reclamation Plant (HWRP)

## Current Conditions

- Plant Capacity: 450 mgd
  - Average Treated Flow (2016): 250 mgd
  - 47 mgd of water recycling
    - 40 mgd for West Basin for water reuse NPR and IPR (both WB and City of LA customers)
    - 7 mgd for in-plant use, off-setting potable water
- Sewershed: Central and West LA
- Digester Gas Utilization Project





# HWRP: Near-Term

## Near-Term

- Increase delivery to West Basin MWD up to 70 mgd:
  - 16 mgd for protection of water supply at sea water barrier, irrigation, industrial (City of LA customers)
  - 54 mgd for sea water barrier, irrigation & industrial use (West Basin customers)
- Route treated flows to Terminal Island WRP (approx. 30 MGD)
- In-plant uses (35 MGD) – DGUP cooling, Cryo, cleaning and washdowns
- Approx. 2 mgd small scale advanced water treatment facility for LAX & Scattergood Power Generating Station (by 2019)
- Pilot testing of advanced treatment processes





## Considerations For the Future (2040)

- Evaluating large scale IPR/DPR options (up to 100 mgd)
  - Groundwater recharge
  - Exchanges/ Agreements with Local water agencies such as Central Basin

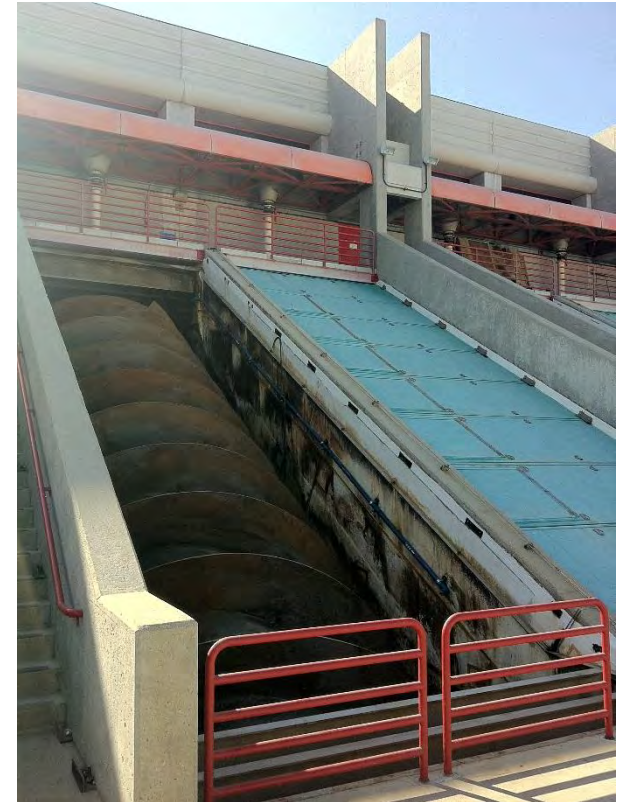



# HWRP: Indirect Potable Reuse

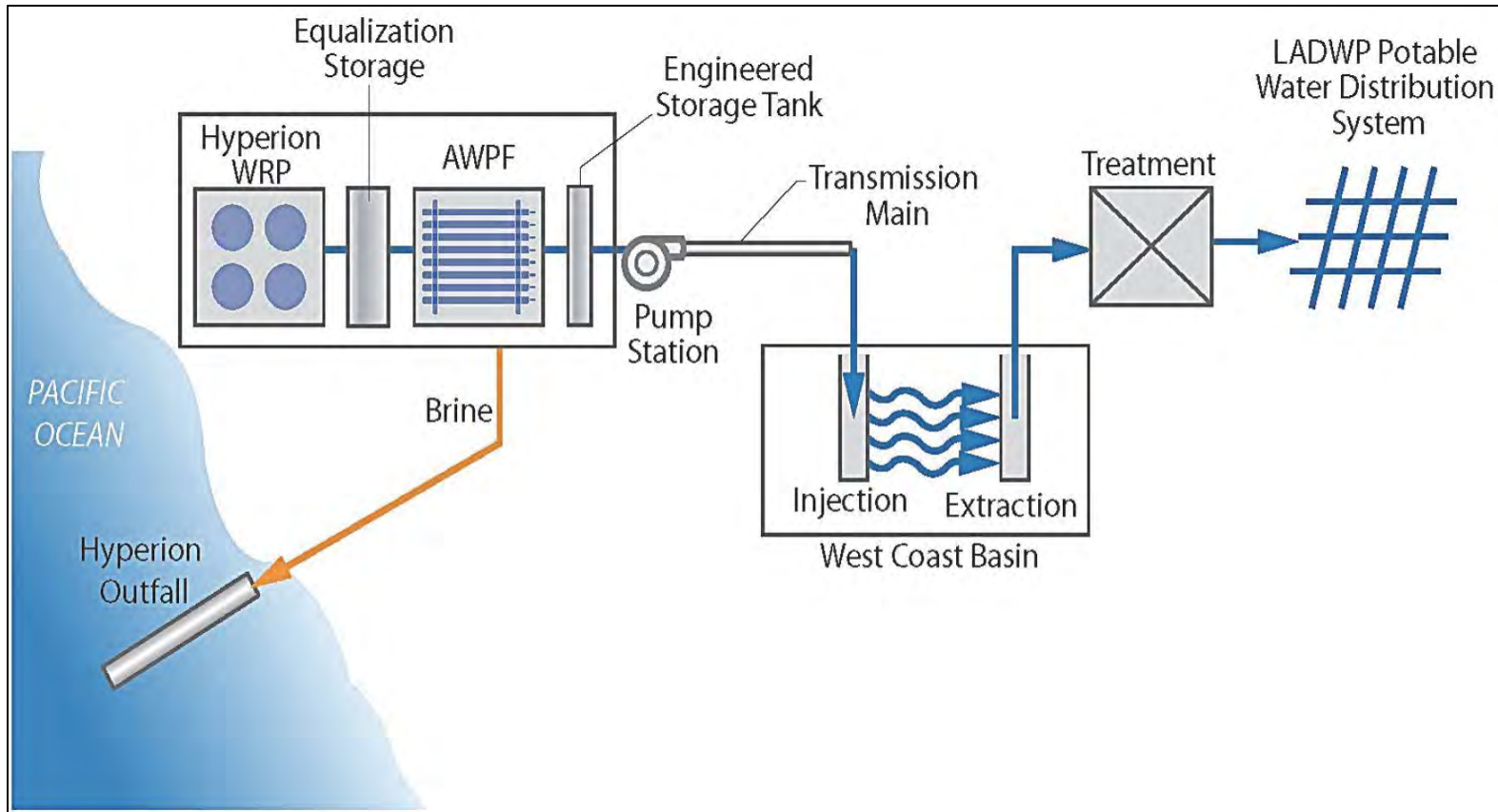



# HWRP: Direct Potable Reuse

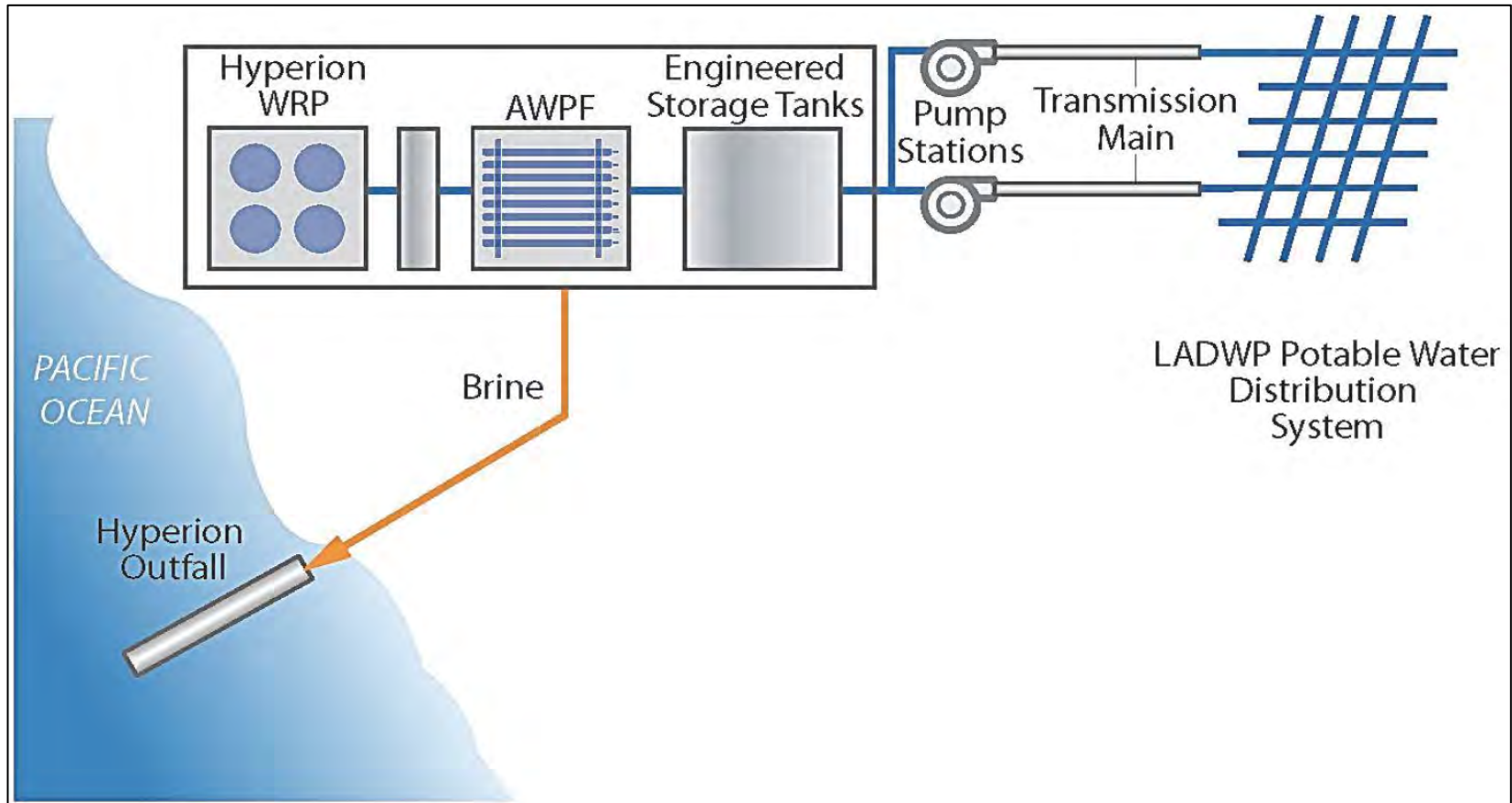



# Terminal Island Water Reclamation Plant (TIWRP)

## Current Conditions

- Plant Capacity: 30 mgd
- Average Treated Flow (2016): 14 mgd
- Sewershed: Harbor Area
- Delivers Advanced treated Recycled Water for:
  - Use in Dominguez Gap Barrier injection wells to block sea water intrusion
  - Harbor area refineries & industries
  - In-Plant Use

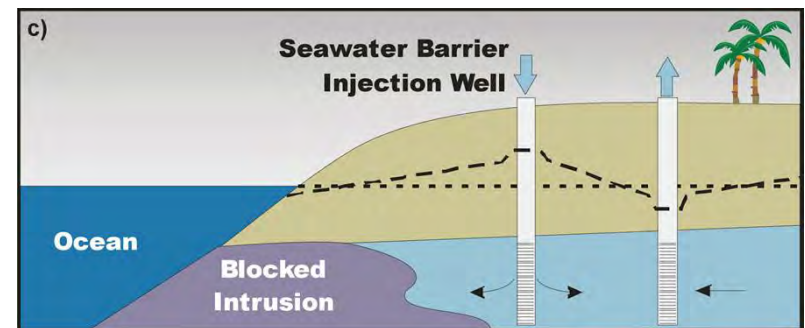



## Near-Term

- Deliver advanced treated water to Machado Lake Recreational Area (0.2 MGD)
- Expand use of Advanced treated Recycled Water for:
  - Industrial Customers in the Harbor
  - 100% recycled water use for Seawater Barrier





## Considerations For the Future (2040)

- Increase plant flows from Hyperion WRP (approx. 30 MGD), stormwater, and other agencies
- Potential changes to solids handling and renewable energy
  - Renewal of Terminal Island Renewable Energy
  - Digester gas



# TIWRP: Future

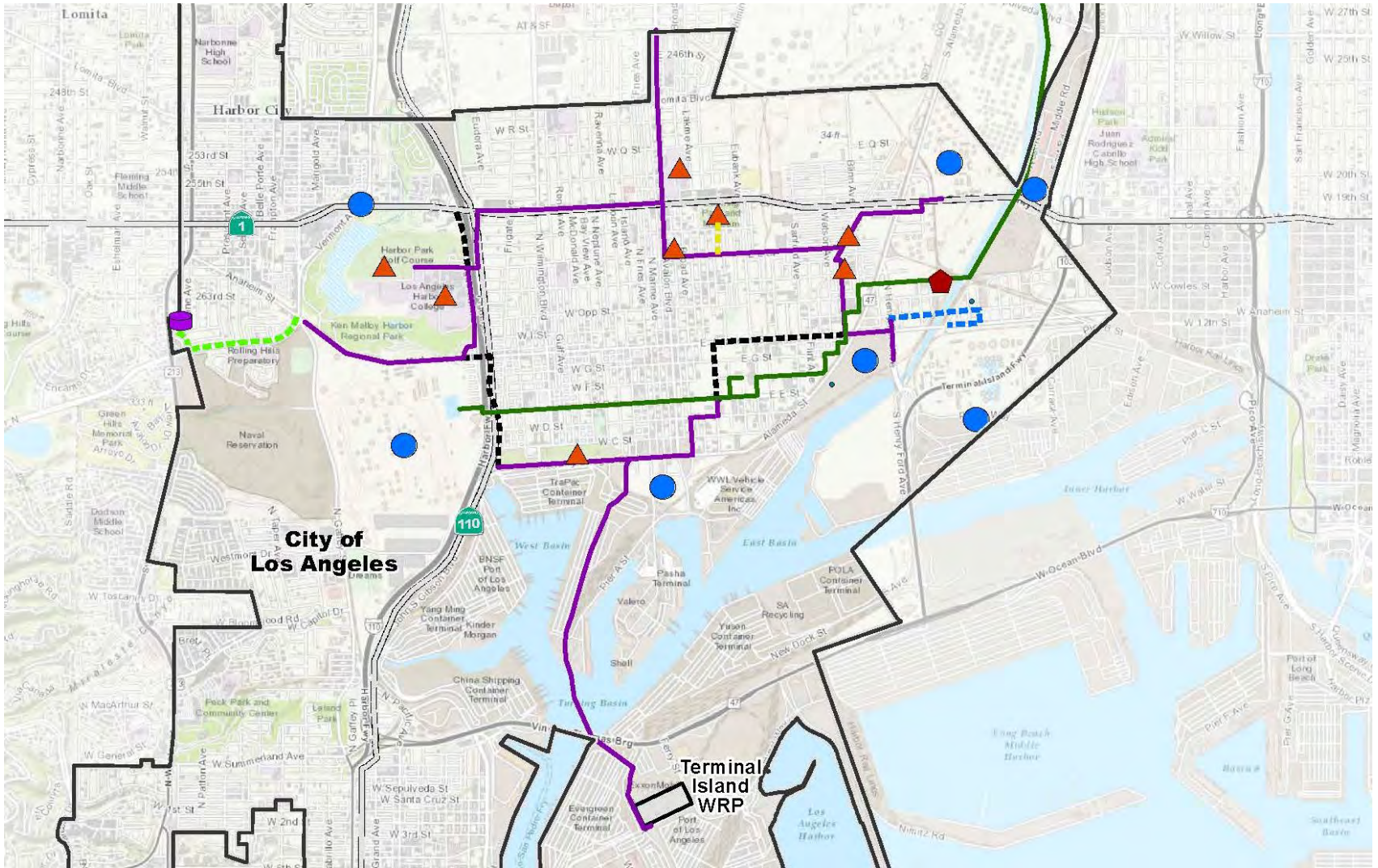

# Status & Next Steps

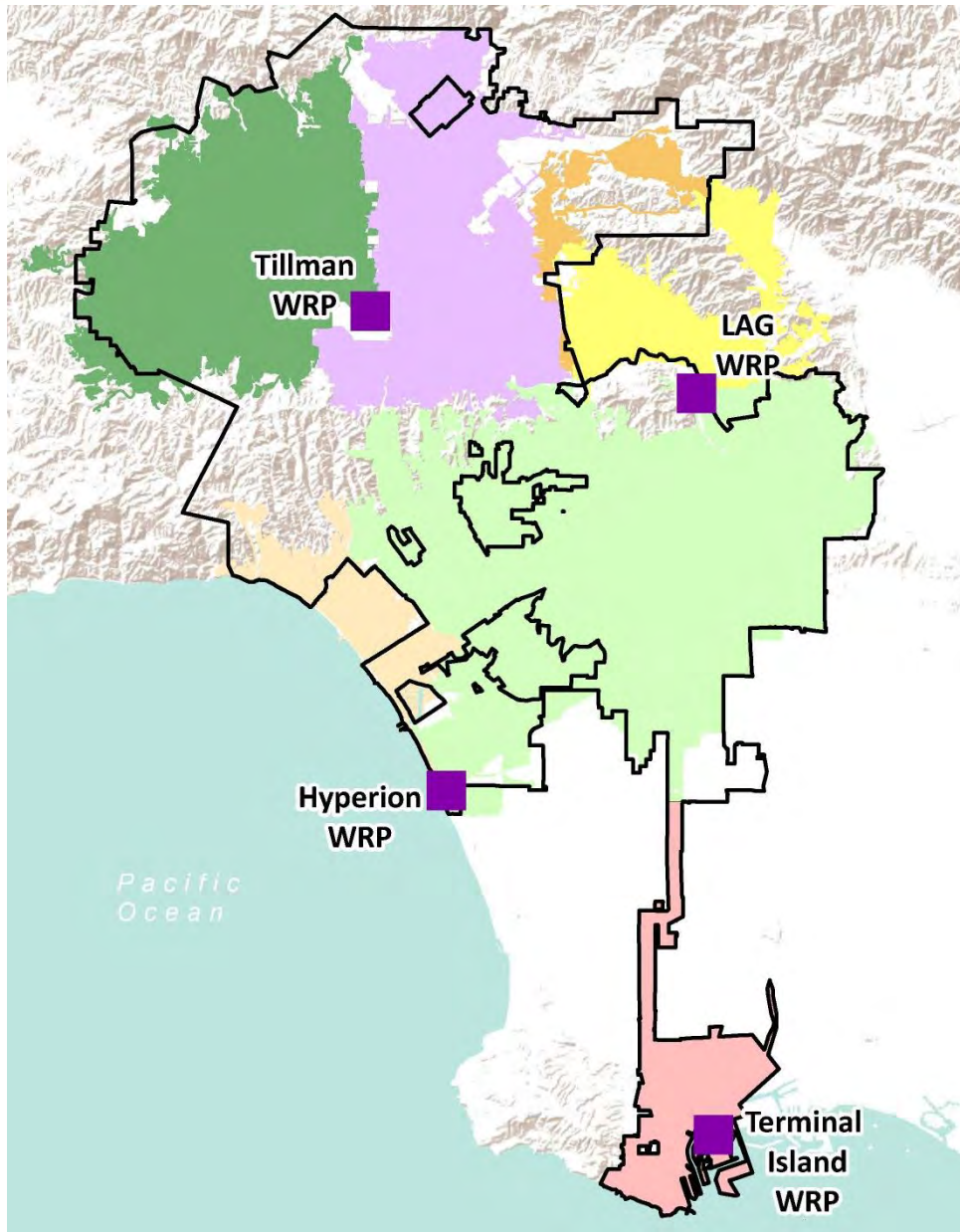

## Facilities Plan Technical Memorandums:

Discuss specific processes, identify issues and needs



## Future System Needs Technical Memorandums:

Identify upgrades & additions

In Progress

## CIP Prioritization Technical Memorandum:

Develop short, mid & long term CIPs



# Stormwater & Urban Runoff Facilities Plan



# Stormwater & Urban Runoff Facilities Plan

## Purpose

To address future system needs through 2040

## Why are we doing it?

To develop a more coordinated and comprehensive approach

- Water quality
- Water supply
- Flood protection
- Sustainability

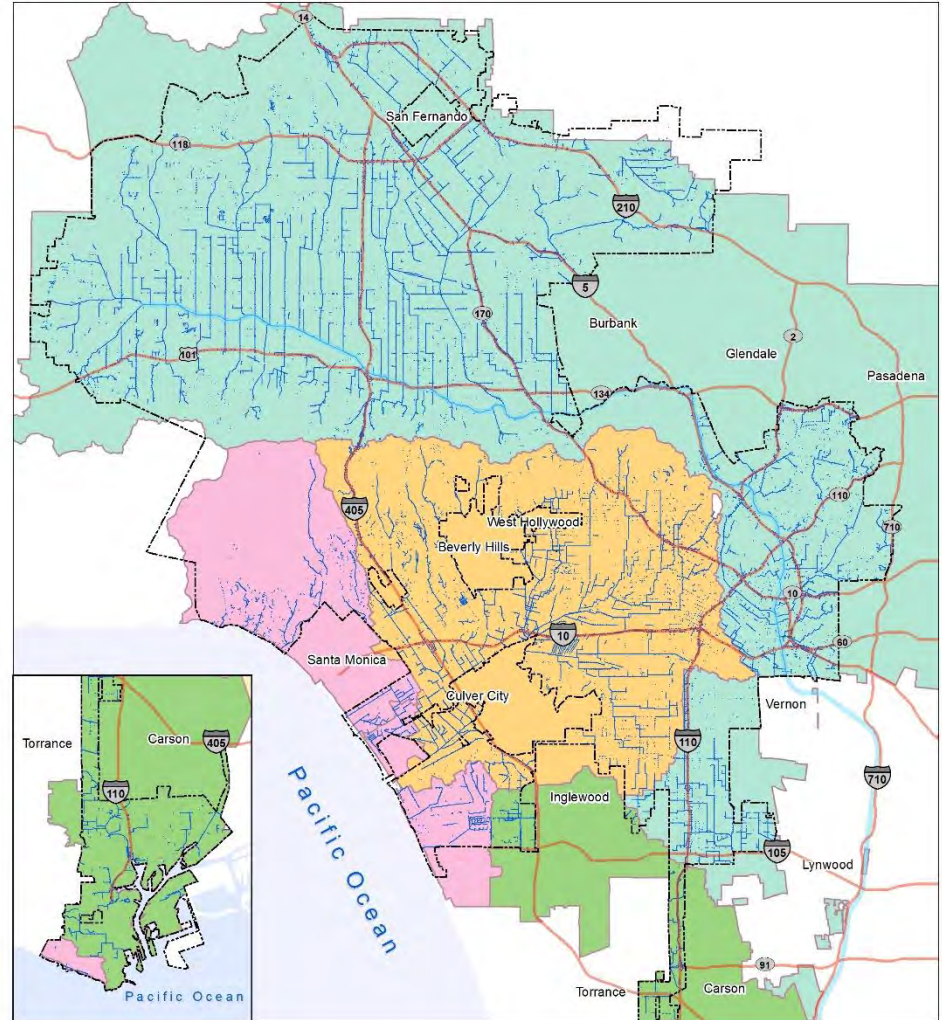

- Stormwater System in City of LA
- Major Freeway (Caltrans ROW)
- Los Angeles River (USACE ROW)
- [- - -] City of LA Boundary
- WMA Boundary**
- Ballona Creek
- Dominguez Channel
- Santa Monica Bay
- Upper Los Angeles River



# Leveraging Previous Stormwater Plans

## 5 Enhanced Watershed Management Plans

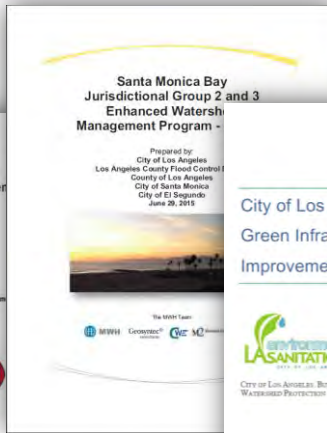
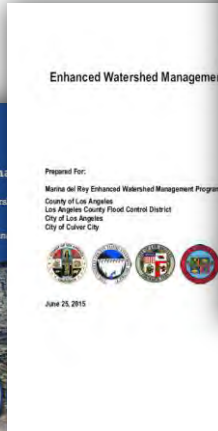
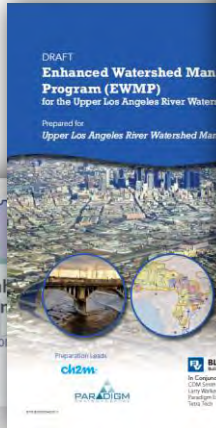

## City of LA Stormwater and Green Infrastructure 5-year CIP

## LA River Ecosystem Restoration Integrated Feasibility Report



## Stormwater Capture Master Plan

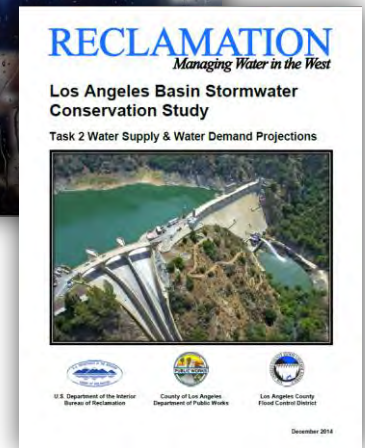
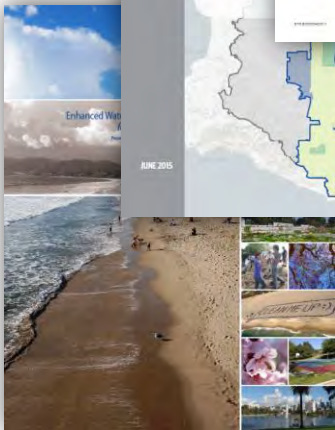
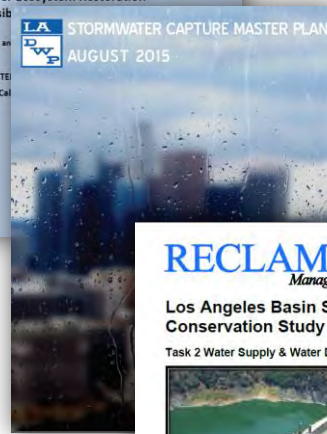

## LA Basin Stormwater Conservation Study



Additional information from City and regional agencies



# Facilities Plan Overview

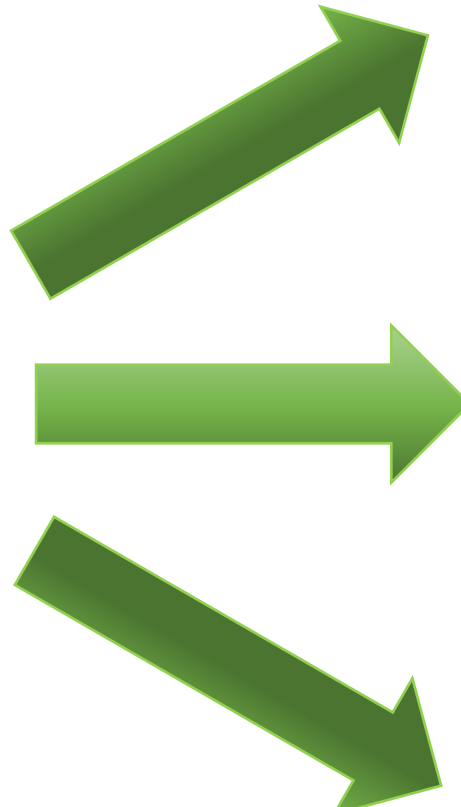

1. Introduction
2. Regulatory Background
3. Stormwater and Dry Weather Runoff Flows
4. Existing Stormwater System
5. Integrated Stormwater Management
6. Operations and Maintenance
7. Stormwater Improvement Program
8. Financing Strategy



# Stormwater System Infrastructure

## Grey Infrastructure

- Storm drains and open channels
- Outfalls
- Road curbs, gutters, and catch basins
- Pump stations
- Low flow diversions that divert to the sewer system
- Debris basins
- Reservoirs and dams

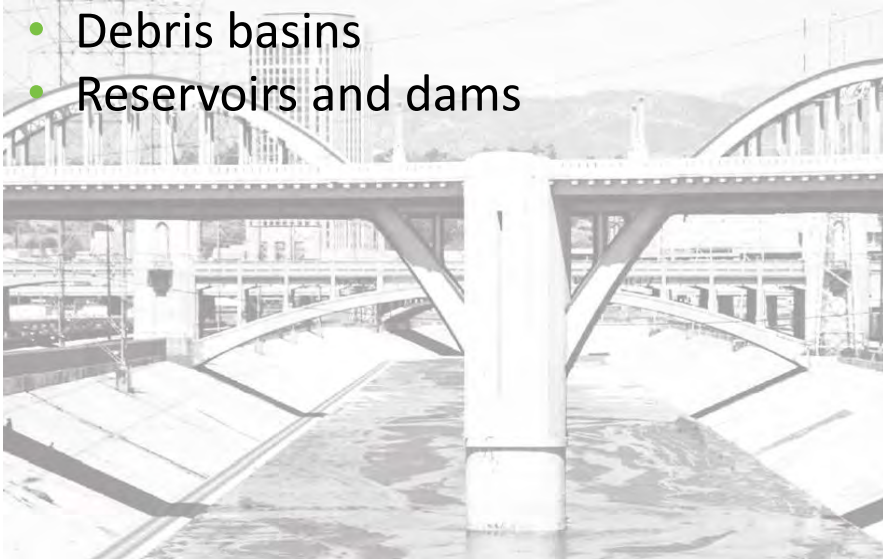

## Green Infrastructure

- Large scale, regional projects:
  - Underground infiltration/retention basins
  - Wetland parks
  - Urban runoff diversion, treatment and storage systems
- Small scale, distributed projects
  - Road curb swales
  - Dry wells
  - Porous pavement
  - Rain gardens
  - Rain barrels





# Example of Regional Green Infrastructure

**Rory Shaw Wetlands Park** – *A collaborative project led by LA County in collaboration with City of LA and other partners*

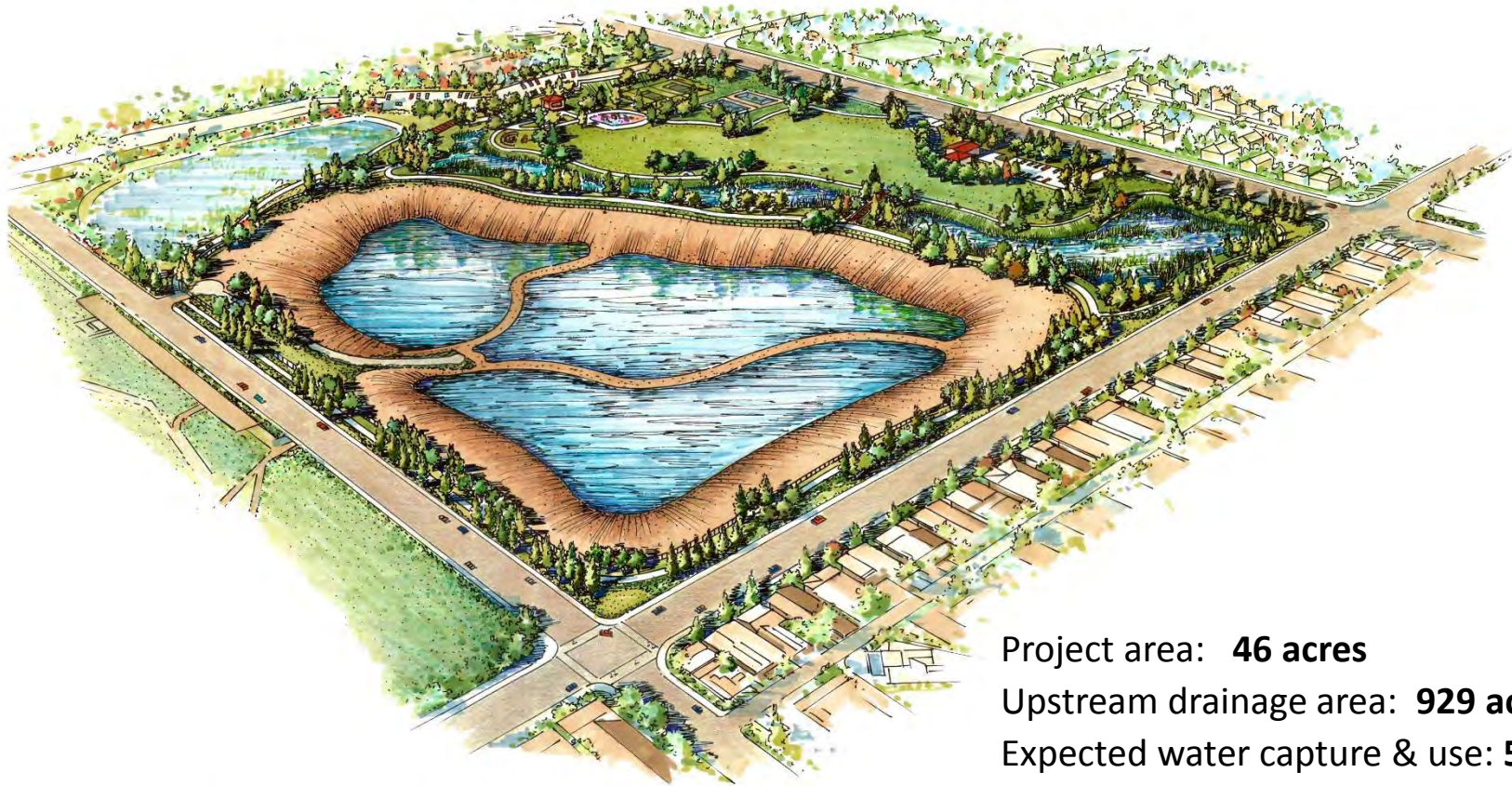

Project area: **46 acres**  
Upstream drainage area: **929 acres**  
Expected water capture & use: **590 ac-ft/yr**



PERSPECTIVE

**RORY M. SHAW WETLANDS PARK**  
CITY OF LOS ANGELES, CALIFORNIA



# Example of Distributed Green Infrastructure

## University Park Neighborhood Rain Garden Pilot Study



- 35 rain gardens (e.g., parkway bioswales) designed and built to capture residential and commercial roadway runoff
- Landscaping features three drought-tolerant plant palettes
- Community engaged and involved during design and construction





# Integrated Stormwater Planning

## What is the 3-Legged-Stool Approach?

An integrated stormwater management planning approach that considers:

- Flood risk mitigation
- Water supply benefit
- Water quality improvement

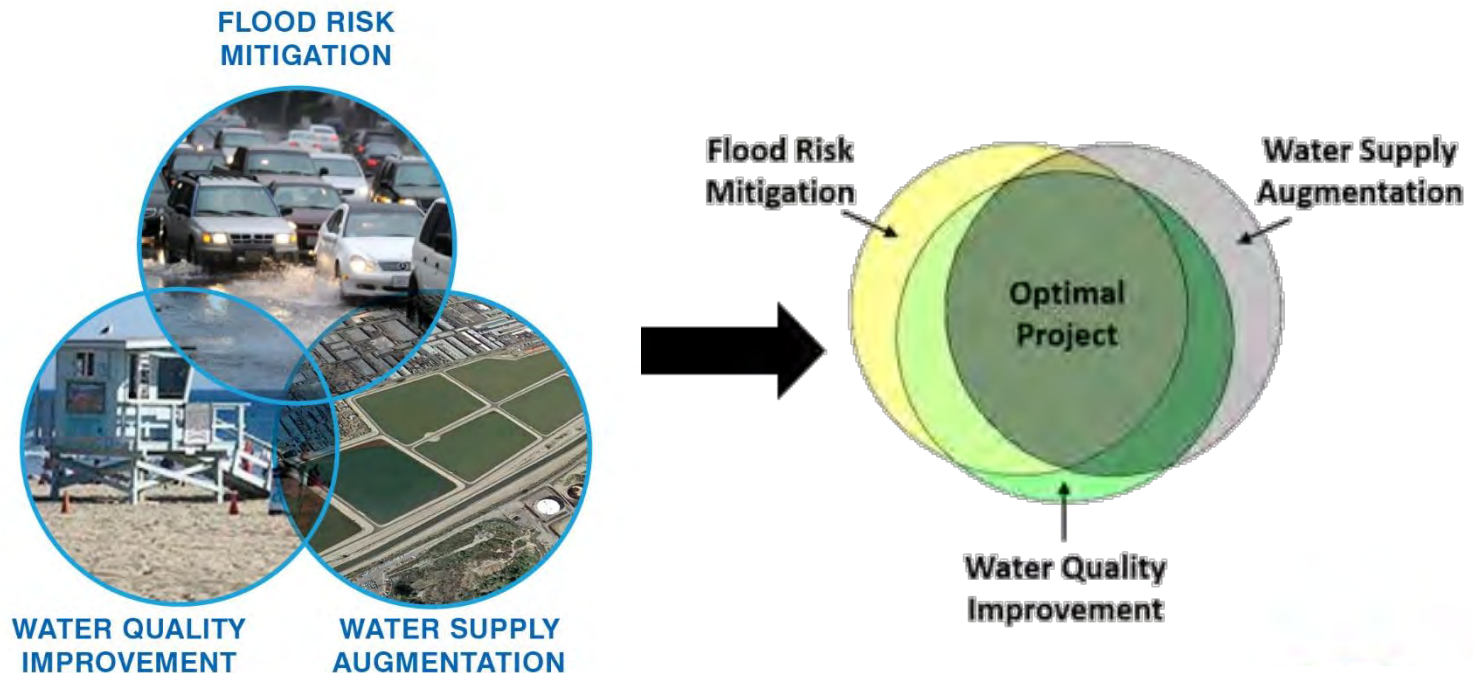



# Stormwater Improvement Program (SIP)

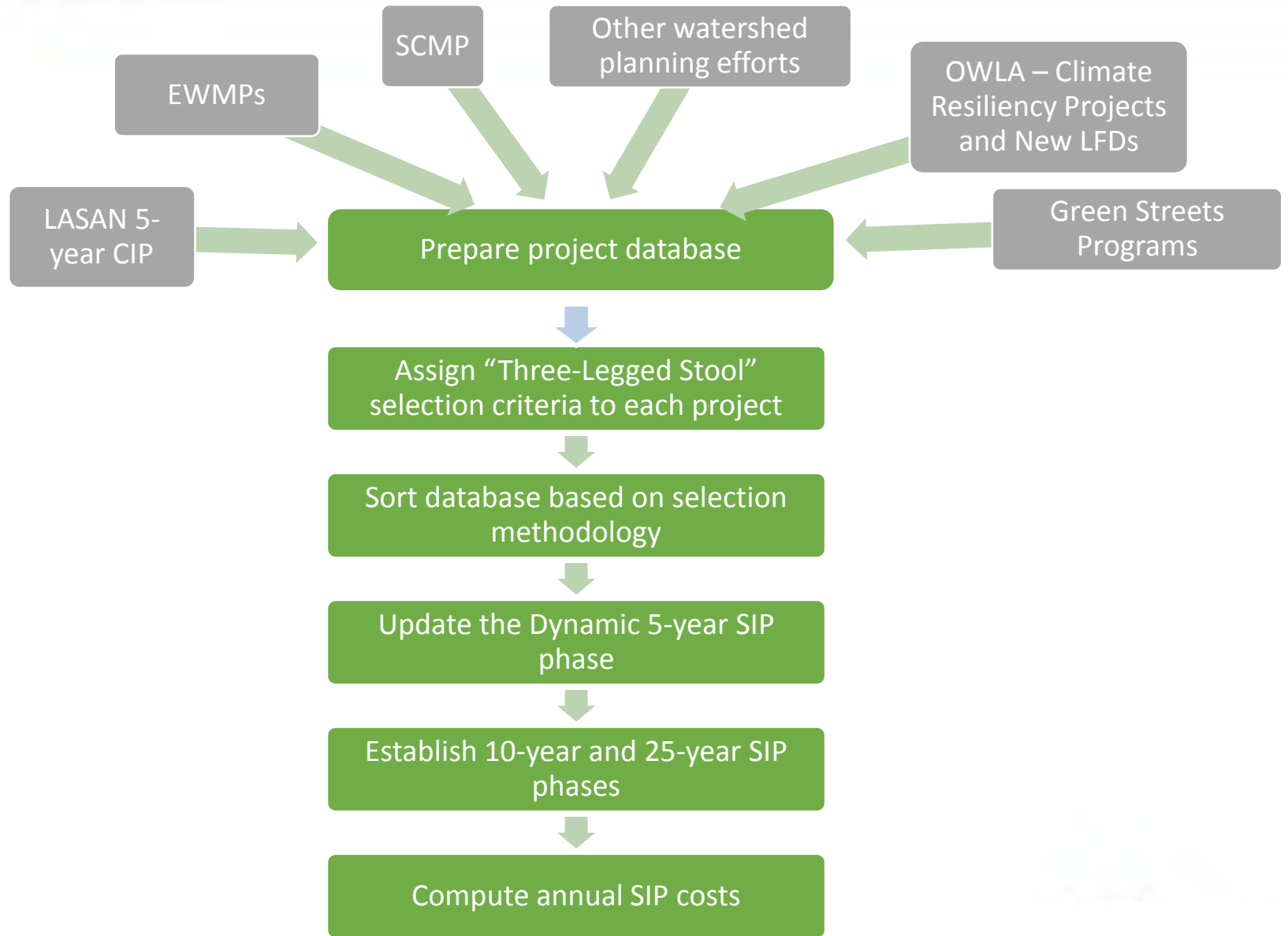



# Project Distribution by Three-Legged Stool

- 1,201 planned/potential projects identified:
  - 308 projects meeting all criteria
  - 614 projects meeting two criteria
  - 279 projects meeting one criteria

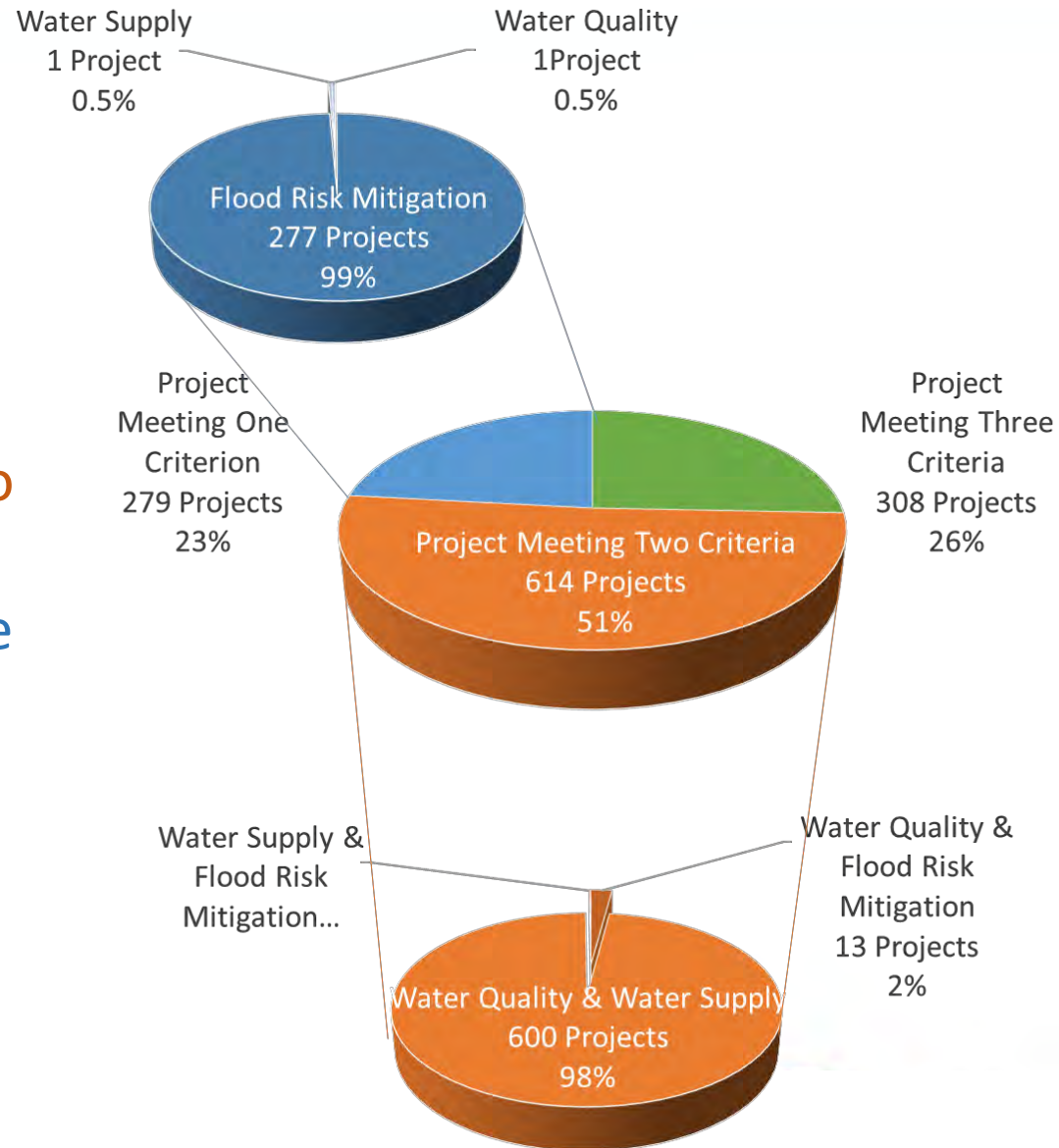



# Project Distribution By Ownership

- **City Lead Projects:** Projects proposed by a City agency (LASAN, LABOE, LADWP, etc.)
- **Collaborative Projects:** Projects proposed by a non-City agency or entity (LACFCD, ACOE, NGOs, etc.) with City agency or funding
- **Non-City Projects:** Projects identified without current participation from any City agency

Only City-led and collaborative projects (1,142 out of the 1,201 projects) were included in the City's Stormwater Improvement Program

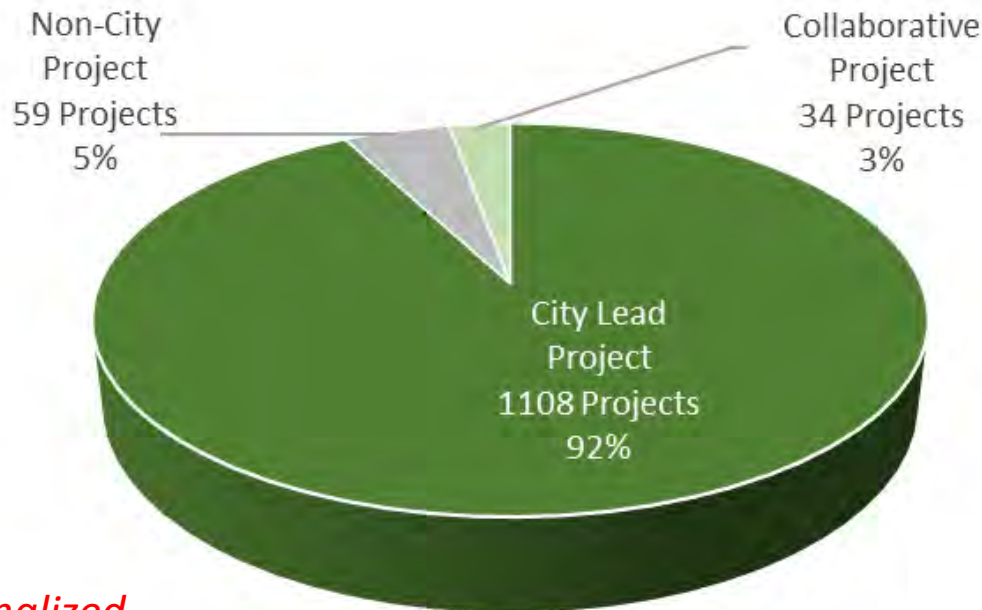



# Stormwater Improvement Program (SIP)

SIP Phase	Implementation Period	Number of Projects	Estimated Capital Cost (\$M)	Estimated O&M Cost (\$M/year)
5-year SIP phase	2017 - 2022	390	\$2,350	\$140
10-year SIP phase	2022 - 2027	206	\$800	\$40
25-year SIP phase	2027 – 2042	546	\$2,450	\$70
			<b>\$5.6B TOTAL</b>	<b>\$250M PER YEAR</b>

\*Costs are initial estimates. The EWMPs report a \$7.3B and concepts are in process to allow for capitalization. Previously planned projects are included in the task 5 In-progress projects section.



# Project Type Breakdown

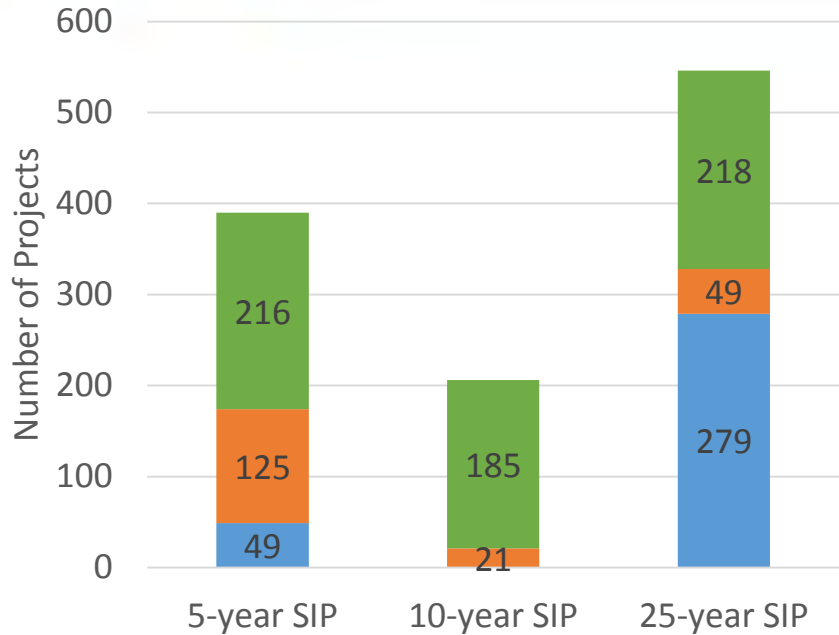

- Category 3 - Distributed Green Infrastructure
- Category 2 - Regional Green Infrastructure
- Category 1 - Regional Grey Infrastructure

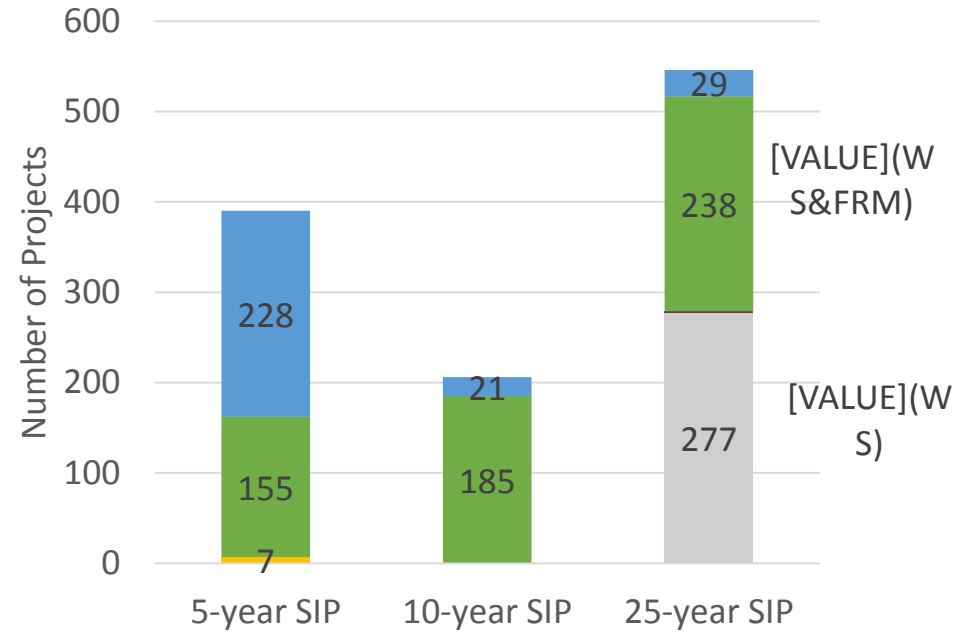

- Water Quality & Water Supply & Flood Risk Mitigation
- Water Quality & Water Supply
- Water Quality & Flood Risk Mitigation
- Water Supply & Flood Risk Mitigation
- Water Supply
- Flood Risk Mitigation



# Project Cost Breakdown



- Category 3 - Distributed Green Infrastructure
- Category 2 - Regional Green Infrastructure
- Category 1 - Regional Grey Infrastructure

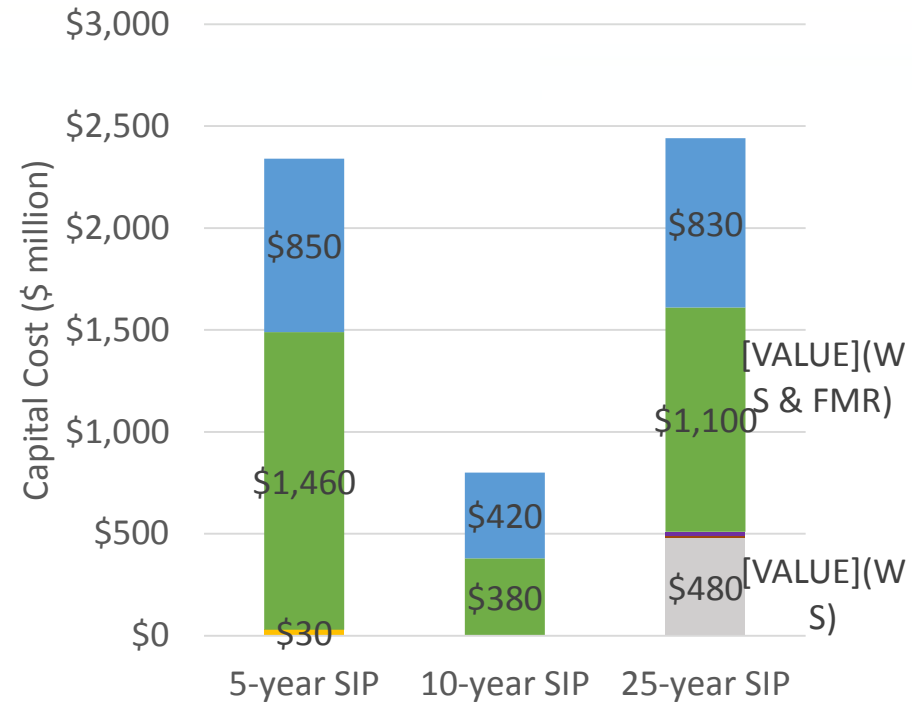

- Water Quality & Water Supply & Flood Risk Mitigation
- Water Quality & Water Supply
- Water Quality & Flood Risk Mitigation
- Water Supply & Flood Risk Mitigation
- Water Supply
- Flood Risk Mitigation



# O&M Cost Breakdown



- Category 3 - Distributed Green Infrastructure
- Category 2 - Regional Green Infrastructure
- Category 1 - Regional Grey Infrastructure

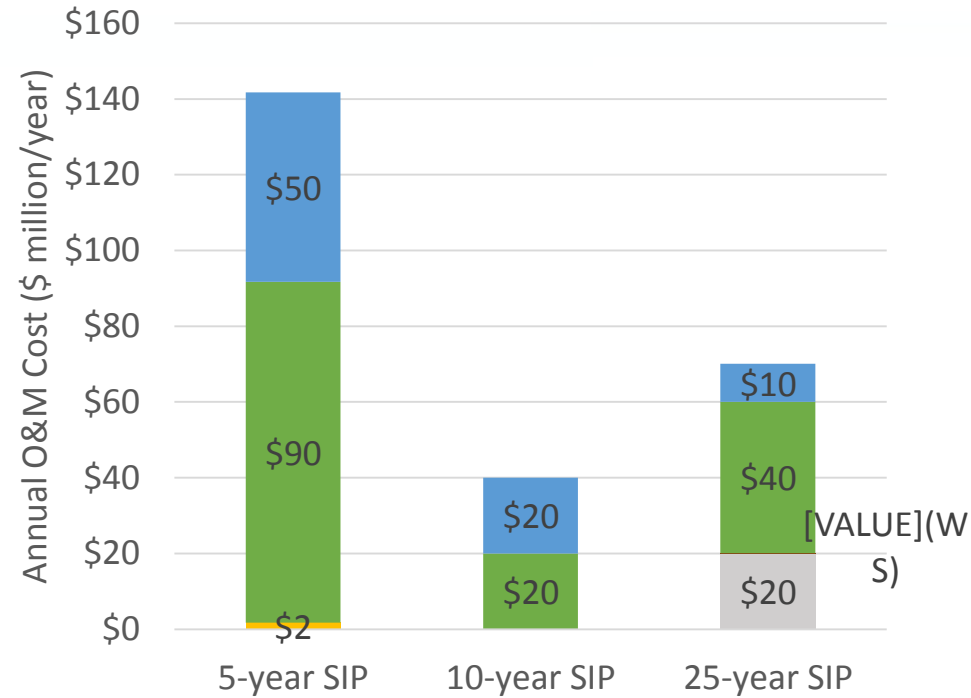

- Water Quality & Water Supply & Flood Risk Mitigation
- Water Quality & Water Supply
- Water Quality & Flood Risk Mitigation
- Water Supply
- Flood Risk Mitigation



# Annual SIP Calculation

- Capital Cost is amortized by:
  - 20% Pay-As-You-Go (PAYGO)
  - 80% Financing
  - 4.5% Interest Rate
  - 30 Years Borrowing Period
  - 1-Year Debt Issuance
- O&M Cost is assumed to cumulatively increase until all SIP projects are implemented



# Annual SIP Cost Projection

- Annual SIP Cost Overview – Constant Dollar Value
  - Neglect Inflation Factor

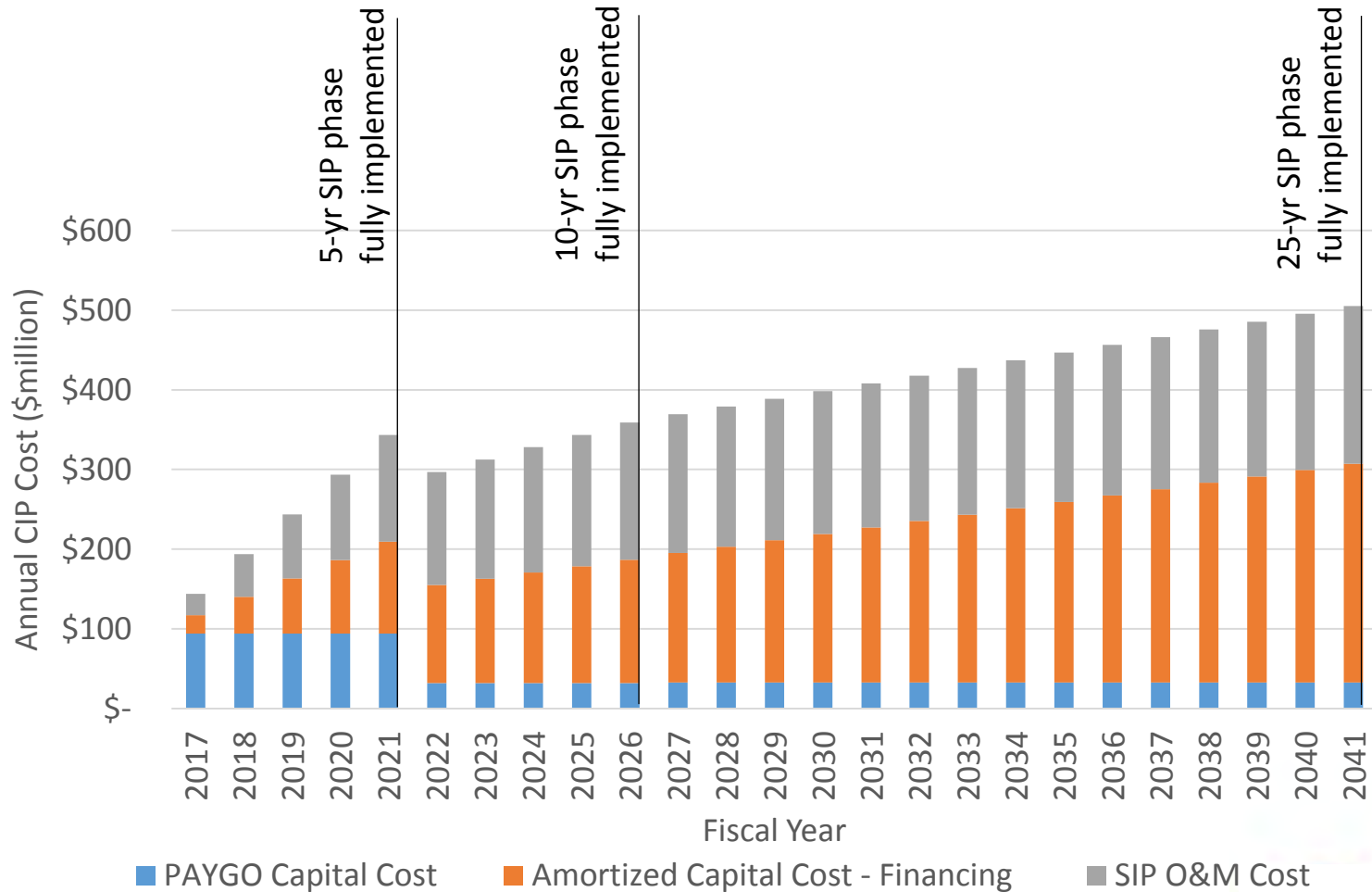



# Funding Assumptions

## Projected Sources of Funding built from:

- Existing Revenue Sources
  - \$28M/YR SPAF - \$23 per parcel per year, 1.2M parcels
  - \$2M/YR in grant funding
  - \$1.2M/YR from developer plan review fees
  - Future projections do not rely on the General Fund (\$13 Million Recent)
    - Used as cost recovery and this is not an accessible fund
- Additional Potential Revenues
  - ~\$72M/YR from LA County Fee - \$54 per parcel per year, 1.4M parcels (escalates with inflation).
  - ~\$Variable LADWP Water Supply (continuous)
- Potential Partnerships and Offsets
  - ~\$5M/YR from Measure A
    - G.O. bond proceeds assumed to be used cooperatively. Examples include Albion Riverside Park, Aliso Creek Confluence Park, etc
  - ~\$20M from Measure M
    - Funding derived from transportation sales tax – reduces City costs to address transportation related water quality impacts



# Projected Revenue Requirements

- O&M obligations = \$44 million, plus O&M from CIP
  - Recent Capital Projects O&M increases not shown
  - Inflation of O&M = assumed inflation rate for all costs (2%)
- Assumed debt financing used to smooth revenue requirements from Capital Projects
  - Historic inability to issue debt due to insufficient revenues and reliance on General Fund
  - Prop O has been principal source of capital funds helping City meet trash and bacteria TMDLs
  - LADWP has translated anticipated annual funding into capital subvention
- Debt Assumptions
  - 20% of Capital Funded PAYGO
  - 80% of Capital Funded from 30-yr Bonds (5%)



# Funding Strategy

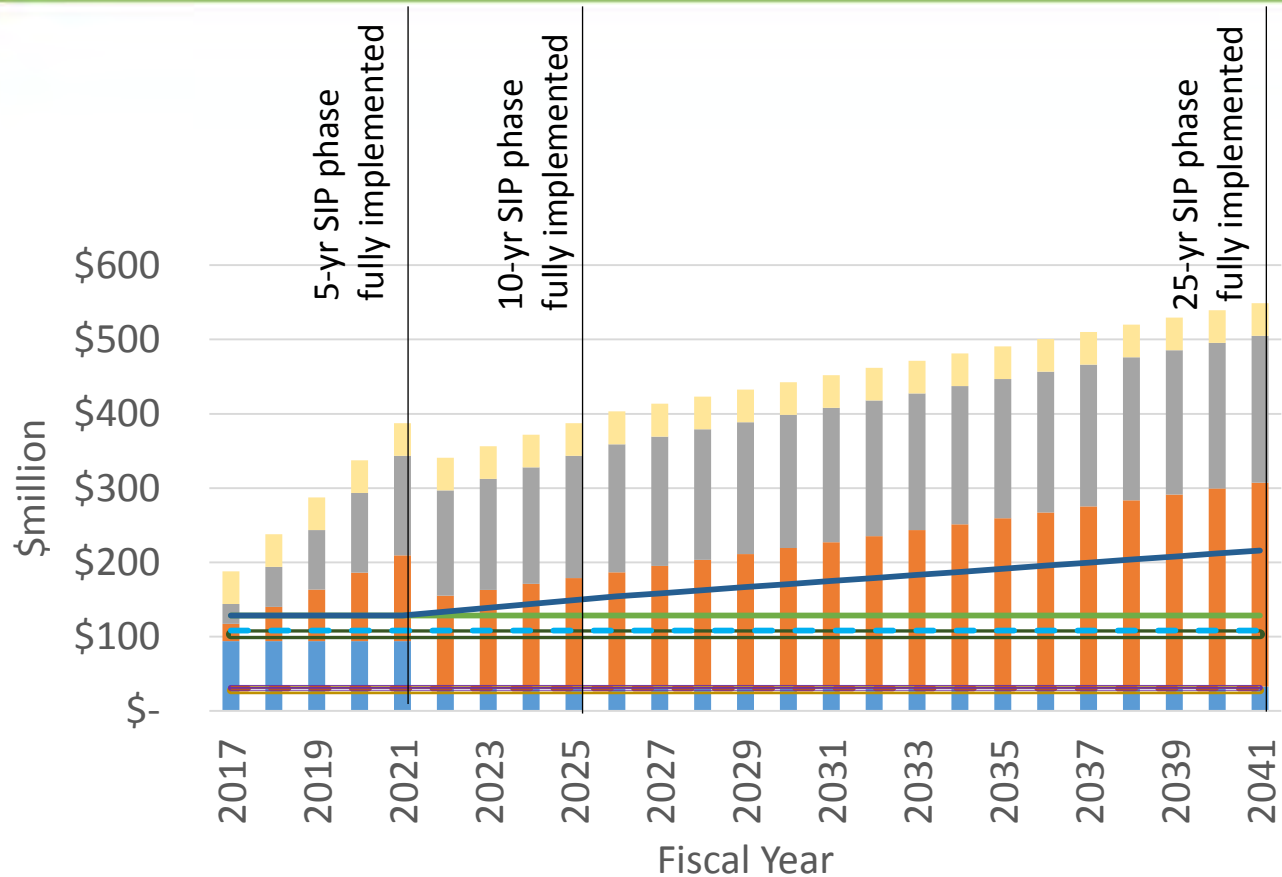

- Existing Projects O&M (\$44M/yr)
- Amortized Capital Cost - Financing
- Water Supply Value (Various)
- Measure A (\$5M/yr)
- Plan Review (\$(\$1.2M/yr)
- SPAF (\$28M/yr)
- SIP O&M Cost
- PAYGO Capital Cost
- Measure M (\$20M/yr)
- LAC Parcel Fee Revenue (\$72M/yr)
- Grants (\$2M/yr)



# Other Funding Strategies

- Other Potential Strategies Under Consideration
  - New Revenues (Taxes)
    - Property Tax
    - Sales tax
    - Gas tax
    - Transient occupancy tax
    - Other
  - Financing options
    - Bonds associated with new taxes above
    - Clean Water State Revolving Fund
    - Water Infrastructure Finance Innovation Act
    - Public-private partnership Financing
    - Other
  - Volunteerism
  - Additional Policies and Programs
    - Source Control
    - Private Property Participation



# Additional Benefits

- LASAN has identified:
  - Avoided fines of thousands of dollars per day per pollutant
  - Habitat and open space
  - Local green jobs
  - Climate resiliency and adaptation
  - Public health improvements



